

THE INFLUENCE OF THE ROTOR ARCHITECTURE OF A ROTATING WORKING MACHINE ON THE DRIVING POWER

Antonios DETZORTZIS¹, Nicolae BĂRAN², Malik N. HAWAS³

This paper presents a new type of rotating working machine that can be used as a pump, fan, and blower; in theoretical and experimental research, the working fluid is air, it will be analyzed as a blower, as low pressure compressor.

The machine is equipped with two profiled rotors that can be constructively performed in two versions:

I) profiled rotor with constant thickness;

II) specially manufactured rotor.

For the two versions, the power lost by viscous friction between the rotor and the machine case walls is calculated. In the end of the paper, the theoretical research are validated by measurements performed on an experimental installation designed and constructed in the laboratory of the Department of Thermodynamics, Engines, Thermal and Refrigeration Equipment from University Politehnica of Bucharest.

Keywords: Rotating machine, profiled rotors, driving power.

1. Introduction

The "rotating machine" term relates to the fact that the presented construction solution can be used as a fan, pump, low-pressure compressor, and blower.

This paper is a contribution to the theoretical and experimental research in the field of rotating compressors with application to the study of profiled rotors.

The study of profiled rotors architecture is complex; it requires thermodynamics, mechanics, mathematical analysis, computer programming notions.

The profiled rotor architecture is a figure, which, following the researchers conducted over time, changes in shape.

¹ PhD. Stud., Dept. of Thermotechnics, Engines, Thermic and Refrigeration Plants, University POLITEHNICA of Bucharest, e-mail: tony@elrom.net

² Prof., Dept. of Thermotechnics, Engines, Thermic and Refrigeration Plants, University POLITEHNICA of Bucharest, Romania, e-mail: n_baran_fimm@yahoo.com

³ PhD. Stud., Dept. of Thermotechnics, Engines, Thermic and Refrigeration Plants, University POLITEHNICA of Bucharest, Romania, e-mail: maliknhawas@yahoo.com

The aim is to achieve a rotor shape so that the circulated flow rate to be as high as possible and the machine driving power as small as possible.

The paper presents two constructive versions:

I) Version I - profiled rotor with constant thickness;

II) Version II - specially manufactured rotor.

For each version the calculation relations for the flow rate and the driving power of the machine are presented; the power lost by friction between the rotors and the case is calculated.

The theoretical and experimental researches were conducted in the laboratory of the Department of Thermodynamics, Engines, Thermal and Refrigeration Equipment from University POLITEHNICA of Bucharest.

2. Machine with two profiled rotors having constant thickness

2.1. The constructive solution and the operating principle

The machine has two profiled rotors which rotate in the opposite direction within a case (Fig. 1).

The synchronous rotation of the rotors (3, 8) is provided by two gearwheels, which form a cylindrical gear with straight teeth's.

The gear wheels are mounted on the shafts (5) and (9) outside of the machine; during the rotational movement, the rotary pistons (4) enter into the cavities of the adjacent rotor.

The rotor profile shape has been established in [1,2] and the manufacturing technology in [3,4].

With the notations from Fig. 1, the flow rate and the driving power of the machine calculation relations are [5,6,7]:

$$\dot{V} = \pi l z (2 \cdot r_r + z) \cdot \frac{n}{30} [m^3 / s] \quad (1)$$

$$P_m = \dot{V}_m \Delta p = \pi \cdot l \cdot z \cdot (2 \cdot r_r + z) \frac{n}{30} \cdot \Delta p [W] \quad (2)$$

where n - the machine rotation, Δp - the increase in pressure between suction and discharge [N/m^2].

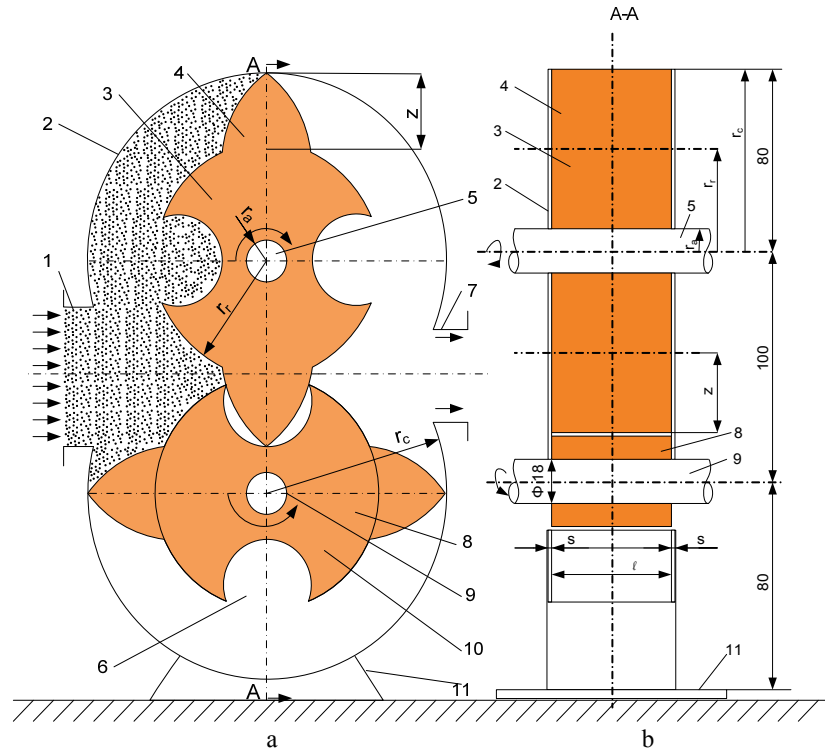

Fig. 1. Cross section (a) and longitudinal section (b) through the blower
 1-gas suction connection; 2-upper case; 3-upper rotor; 4- rotating piston; 5-driven shaft; 6-cavity;
 7-gas discharge connection; 8-lower rotor; 9-driving shaft; 10-contact surface between the rotor
 and the case wall; 11-support
 r_a - shaft radius; r_r - rotor radius; z - piston height

2.2. The determination of lost power through viscous friction between the rotors and the side walls of the case (Version I)

Calculation hypotheses:

- The friction between the top of the piston and the case is neglected.
- The front surface of the piston completes the cavities created in the rotor, so the calculation area is from r_a to r_r (fig. 1).
- The fluid velocity at each point on the front surface of the rotor is equal to the rotor velocity.
- The velocity at a point on the surface of the disk will be in the range of:

$$w_a = \omega \cdot r_a \text{ and } w_r = \omega \cdot r_r \quad [m / s] \quad (3)$$

It is required to establish the consumed power through viscous friction between the front surfaces of the rotors and the case walls.

As initial data are known:

- The shaft radius on which the rotor is mounted: $r_a = 9 \cdot 10^{-3} \text{ m}$; the rotor exterior radius: $r_r = 50 \cdot 10^{-3} \text{ m}$;

-The angular velocity for a given rpm of the disk;

- The dynamic viscosity of air at $t = 20 \text{ }^\circ\text{C}$ is found from [8,9]:

$$\bullet \quad \eta_{air} = 18.5 \cdot 10^{-6} \frac{\text{N} \cdot \text{s}}{\text{m}^2}$$

-The gap between the disk and the case walls is chosen equal to the CNC precision processing [10]: $s = 0.01 \cdot 10^{-3} \text{ m}$.

The calculation is made for one rotor. From mechanics is known that the torque is the product between the force and the force arm. The elementary resistant torque due to viscous friction between the rotor and the two walls of the case will be [11]:

$$dM_r = 2r dF_f \quad (4)$$

where F_f is the viscos friction force.

$$dF_f = \tau dA \quad (5)$$

τ - tangential effort; dA – elementary surface area (Fig.2).

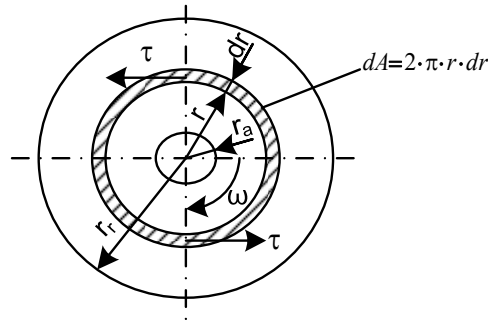

Fig. 2. Plan view of a portion of the rotor

$$dA = 2\pi r \cdot dr \quad (6)$$

The tangential tension (shear stress) due to fluid viscosity is calculated with Newton formula [12,13]:

$$\tau = \eta \frac{dw}{dy} \quad (7)$$

where the coordinate y is measured perpendicularly to the disk surface (Fig. 3).

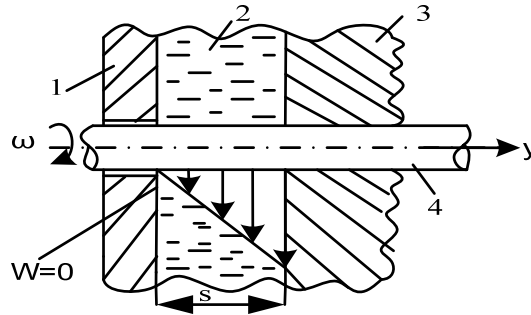

Fig. 3. Computing section
1- case; 2- thin layer of fluid; 3- rotor disk; 4-shaft

The velocity gradient for the boundary layer with "s" thickness, assuming a linear variation, has the expression:

$$\frac{dw}{dy} = \frac{\omega r}{s} \quad (8)$$

Equation (8) becomes:

$$\tau = \eta \cdot \frac{\omega r}{s} \quad (9)$$

Equation (5), taking into account equation (6) and (9) becomes:

$$dF = \eta \cdot \frac{\omega \cdot r}{s} \cdot 2\pi r dr = 2\pi r^2 \eta \frac{\omega}{s} dr \quad (10)$$

A more exactly calculation can be performed using the dynamic boundary layer theory [14,15].

Form equation (4) and (10) is obtained:

$$dM_r = 2r \cdot 2\pi r^2 \eta \frac{\omega}{s} dr \quad (11)$$

$$\int_0^M dM_r = \int_{r_a}^{r_r} \frac{4 \cdot \pi \cdot \omega \cdot \eta \cdot r^3}{s} dr \quad (12)$$

$$M_r = \frac{\pi \cdot \eta \cdot \omega}{s} [r_r^4 - r_a^4] [N \cdot m] \quad (13)$$

From mechanics is known the relation of consumed power computing to overcome the viscous friction for one rotor [11]:

$$P_{1r} = M_r \cdot \omega [W] \quad (14)$$

For the entire machine, the consumed power by viscous friction (P_m) will be:

$$P_m = 2 \cdot P_{1r} [W] \quad (15)$$

Introducing the relations (13) and (14) into (15) it results:

$$P_m = 2 \frac{\pi \cdot \eta \cdot \omega^2}{s} \cdot (r_r^4 - r_a^4) \quad (16)$$

From equation (16) is observed that for a given constructive solution the value of P_m is influenced by η and ω^2 .

In what follows, the influence of the rotor architecture (version I and version II) function of ω , the value of η remaining constant, is studied.

Is calculated the power lost by viscous friction between the frontal surfaces of the rotors and the case walls with the values of η for air and ω given by $n_r = 200, 400, 600r, 800, 1000$ rpm.

$$\omega_1 = \frac{2\pi n_r}{60} = \frac{\pi}{30} 200 = 20.93 \text{ rad / s} \quad (17)$$

$$P_m = 2 \cdot \frac{3.14 \cdot 18.5 \cdot 10^{-6} \cdot (20.93)^2}{0.01 \cdot 10^{-3}} \left[(50 \cdot 10^{-3})^2 - (9 \cdot 10^{-3})^2 \right] = 0.031 \text{ W} \quad (18)$$

Similarly the calculations are made for other values of n_r , resulting the data in Table 1.

Table 1

Values of $P_m=f(n_r)$ for version I

n_r [rot/min]	200	400	600	800	1000
ω [rad/s]	20.933	41.866	62.799	83.680	104.660
P_m [W]	0.031	0.127	0.286	0.508	0.791

Based on the data in Table 1, the curve $P_m = f(n_r)$ is plotted (Fig. 4).

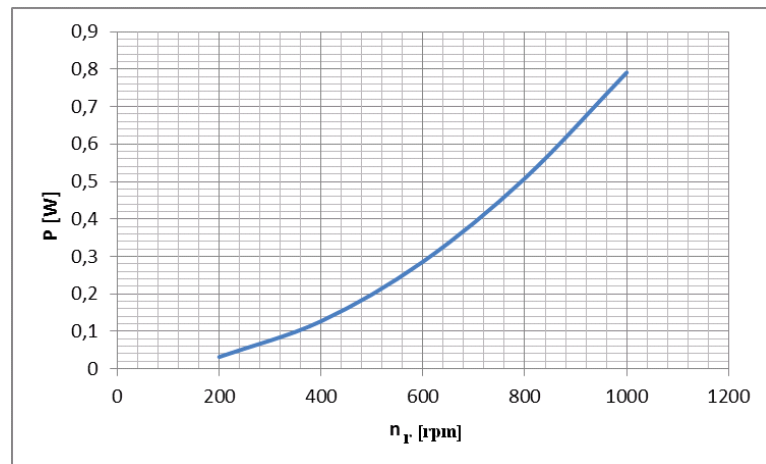

Fig. 4. $P_m = f(n_r)$ for air, version I

From Fig.4 it is found that with the machine rpm increase, the power consumed by viscous friction between the machine rotors and the case the will increase; the necessary driving power of the machine will increase.

3. Machine with two specially profiled rotors

3.1. The constructive solution and the operating principle

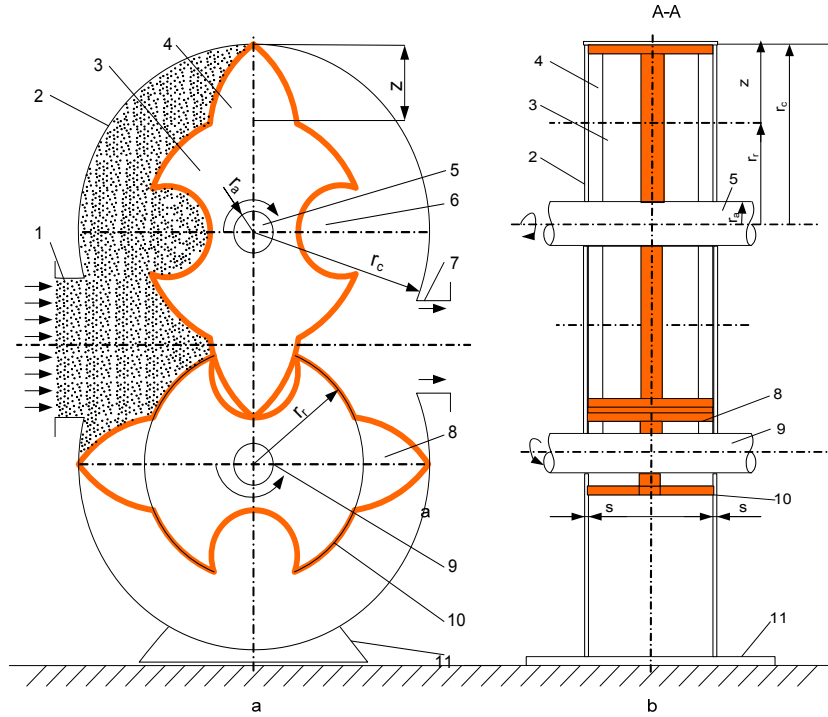

Fig. 5. Cross section (a) and longitudinal section (b) through the rotating blower
 1-gas suction connection; 2-upper case; 3-upper rotor; 4- rotating piston; 5-driven shaft;
 6-cavity; 7-gas discharge connection; 8-lower rotor; 9-driving shaft; 10-contact surface between
 the rotor and the case wall; 11-support

In order to better understand the constructive solution in version II, there has been made a photo of the case without the cover (Fig. 6).



Fig.6. Specially profiled rotor mounted in the case

From Fig. 6 one observes that not all the lateral surface of the rotors comes in contact with the side walls of the case.

The operating principle of the machine is the same as that described in section 2.1.

3.2. Determination of the lost power through viscous friction between the rotors and the side walls of the case (Version II)

Similarly as in Paragraph 2.2. the power consumed by friction between the two rotors and the side walls of the case is:

$$P_m = 2 \cdot \frac{\pi \cdot \eta \cdot \omega^2}{s} [r_r^4 - r_i^4] \quad [N/m] \quad (19)$$

where r_i is the inner radius of the rotor; $r_i = 45 \text{ mm}$;

$$P_m = 2 \cdot \frac{3.14 \cdot 18.5 \cdot 10^{-6} \cdot (20.939)^2}{0.01 \cdot 10^{-3}} \left[(50 \cdot 10^{-3})^2 - (45 \cdot 10^{-3})^2 \right] = 0.010 \text{ W} \quad (20)$$

Similarly, the calculation for $n_r = \text{rot/min}$ 400, 600, 800, 1000, are made, resulting the data in Table 2.

Table 2

Values of $P_m = f(n_r)$ for version II

n_r [rot/min]	200	400	600	800	1000
ω [rad/s]	20.933	41.866	62.799	83.680	104.660
P_m [W]	0.010	0.043	0.098	0.174	0.273

Based on the results in Table 2, the curve $P_m = f(n_r)$ is plotted in Fig. 7.

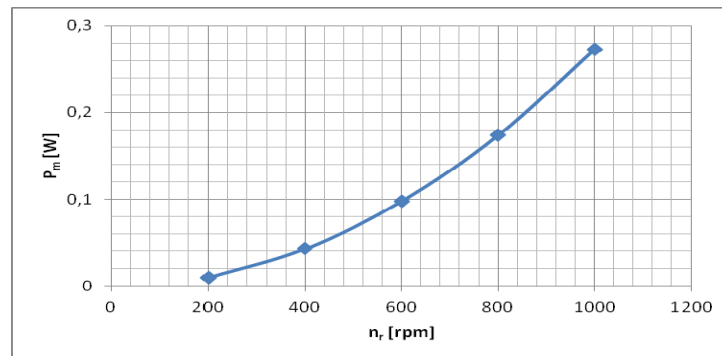

Fig. 7. $P_m = f(n_r)$ for air (version II)

If graphs from Fig. 4 and from Fig. 7 are overlapped on the same drawing one obtains Fig. 8:

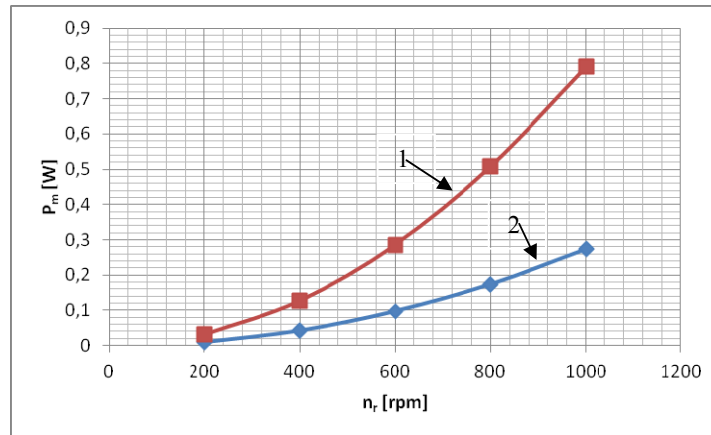

Fig. 8. $P_m = f(n_r)$ for air
1- $P_m = f(n_r)$ version I; 2- $P_m = f(n_r)$ version II;

Figure 8 shows that with the machine rpm increase, the power consumed by viscous friction between the machine rotors and the case will increase; the machine constructive solution in version II will be more advantageous because the power consumed to defeat the viscous friction is lower.

4. Experimental researches

4.1. Experimental stand description

The stand was designed so that the performed measurements solve the following problems:

- a) - The influence of rotor shape on the driving power;
- b)-The construction through experiments of the simple characteristics of

the machine: $\dot{V} = f(n_r); P = f(n_r); \eta = f(n_r)$.

To the stand achievement specialty papers were consulted [16, 17, 18].

From the stand scheme (Fig. 9) it follows that the main parameters: the flow (pressure, temperature), the absorbed power and the blower rpm can be measured.

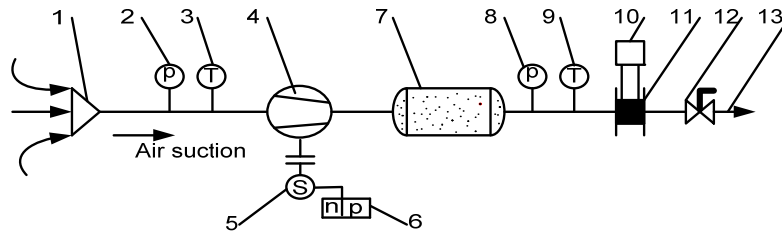

Fig.9. The experimental installation scheme for testing a rotating blower with profiled rotors
 1 air filter; 2-device for measuring the pressure at the blower suction; 3- air temperature measuring device; 4-rotating blower; 5-electric motor; 6-panel with electrical appliances;
 7- compressed air tank; 8-manometer with digital display; 9-thermometer with digital display;
 10-differential manometer; 11- diaphragm; 12- control; 13 DN 50 air discharge valve.

The stand is constructed in open circuit; it allows the measurement of the pressure and air temperature both on suction and discharge from the rotating blower with profiled rotors. Fig. 10 presents a general view of the stand.



Fig.10. Overview of the experimental installation
 1 electric motor; 2 - rotating blower; 3-panel with electrical appliances; 4- compressed air tank; 5-diaphragm for air flow measurement

4.2. Researches methodology and obtained results

- After operating the rotating blower, the control valve (12) is fully open, there is no hydraulic resistance at discharge.

- Thereafter, through the ALTIVAR (6) device [19,20] the rpm of the electric motor (5) is adjusted to the values 200, 400, 600, 800, 1000 rot/ min.

Simultaneously, the power consumed by the electric motor, that is, the power at „backlash ", is read.

- The results of the experimentally measured magnitudes are shown in Table 3.

Table 3

The experimental obtained results

n_r [rot/min]	200	400	600	800	1000
ω [rad/s]	20.933	41.866	62.799	83.680	104.660
P_m [W]	Var. I				
	Var. II				

The power (P_m) consumed by the machine is used to overcome the viscous friction between the rotor and the case walls and to overcome the mechanical friction occurring in the electric motor and blower bearings.

The values of the power absorbed by the machine are higher than the theoretical ones due to the internal and mechanical efficiency that have reduced these values.

5. Conclusions

From the theoretical and the experimental researches it results:

1 - For a given machine constructive solution, the power (P_m) lost by viscous friction between the rotor and the side walls of the case, depends on η and ω^2 .

2 - When the fluid viscosity increases, air, water, oil, the value of P_m will increase.

3 - When the machine rpm increases, the value of P_m will increase.

4 - The profiled rotor shape influences the power lost by viscous friction; therefore, the driving power of the machine is influenced.

REFERENCES

- [1]. *A. Costache, N. Băran*, “Computation method for establishing the contour of a new type of profiled rotor”, University Politehnica of Bucharest, Scientific Bulletin, Series D: Mechanical Engineering, **vol. 70**, no.3, 2008, pp. 93 – 102.
- [2]. *N. Băran, A. Motorga, A. Costache*, “Computing elements regarding the architecture of a profiled rotor”, (in Romanian), Termotehnica, Agir Publishing House, Bucharest, no.1, 2008, pp. 59-63.
- [3]. *N. Băran, D. Besnea, T. Sima, A. Detzortzis, C. Cărnaru*, “Manufacturing Technology for a New Type of Profiled Rotor”, Advanced Materials Research, Trans Tech Publications, Switzerland, **vol. 655-657**, 2013, pp. 235-240,.
- [4]. *N. Băran, O. Donțu, D. Besnea, A. Costache*, “Constructive elements and technological procedures used in the construction of a new type of rotating compressor”, Rev. Fine Mechanics, Optics & Mechatronics, no. 25, 2004, pp. 265-268.

- [5]. *N. Băran*, “Computing elements for a new type of rotating working machine with profiled pistons”, (in Romanian), *Journal of Chemistry*, **vol. 51**, no. 4, 2000, pp. 318-321.
- [6]. *N. Băran, D. Despina, D. Besnea, A. Detzortzis*, “Theoretical and experimental researches regarding the performances of a new type of rotating machine with profiled rotors”, *Advanced Materials Research*, Trans Tech Publications, Switzerland, **vol. 488-489**, 2012, pp.1757-1761.
- [7]. *N. Băran*, “The relation between the driving power and the main constructive elements of a rotating pump”, (in Romanian), *Rev. Fine Mechanics, Optics & Mechatronics*, no. 16, 1999, pp. 1662-1665.
- [8]. *N. Băran, D. Stanciu*, “Technical Thermodynamics”, (in Romanian), MATRIXROM Publishing House, Bucharest, 2001.
- [9]. *Al. Dobrovicescu, N. Băran and col.*, “Technical Thermodynamics Fundamentals”, (in Romanian), **vol. I**, POLITEHNICA PRESS Publishing House, Bucharest, 2009.
- [10]. *V. Tcacenco*, “Alzmetall vertical shaft processing centers”, (in Romanian), *Technical and Technology Journal*, no. 4, Bucharest, 2005, pp. 16-17.
- [11]. *M. Stoian*, “Mechanics and Materials Resistance”, (in Romanian), Didactical and Pedagogical Publishing House, **vol. I**, Bucharest, 1965.
- [12]. *N. Băran*, “Thermal machines, Rotating working machines, Force machines”, (in Romanian), MATRIXROM Publishing House, Bucharest, 2001.
- [13]. *C-tin. Isbăsoiu*, “Treatise of fluid mechanics”, (in Romanian), Agir Publishing House, Bucharest 2011.
- [14]. *H. Schlichting, K. Gersten*, “Boundary Layer Theory”, Springer, 2000.
- [15]. *V. Pimsner, N. Băran*, “The determination of friction losses in the boundary layer on the turbine blades, *Studies and Applied Mechanics*”, (in Romanian), Romanian Academy Publishing House, R.S.R. tom. no. 37, no. 4, Bucharest, 1978, pp. 527-534.
- [16]. *M. Exarhu*, “Hydraulic and pneumatic machines and installations”, (in Romanian), Printech Publishing House, Bucharest, 2010.
- [17]. *M. Exarhu*, “Fundamentals experimental research”, (in Romanian), UPB Publishing House, Bucharest, 2005.
- [18]. *A. Bărglăzan, I. Anton, V. Anton, I. Preda*, “Tests of hydraulic and pneumatic machines”, (in Romanian), Technical Publishing House, Bucharest, 1959.
- [19]. *N. Băran, D. Despina, D. Besnea*, “Researches on a New Type of Rotating Thermic Motor”, *Advanced Materials Research*, Trans Tech Publications, Switzerland, **vol. 463-464**, 2012, pp. 1678-1681.
- [20]. *N. Băran, I. Călușaru, A. Detzortzis*, “Research regarding the testing of a new type of rotating machine with profiled rotors”, *Journal of Material Science and Engineering*, **vol. 2**, USA, no 3, 2012, pp. 372-376.