

Design Sensitivity Analysis for Identification the Optimum Shape and Geometry Optimization by Using Finite Element Method

Hani Mizhir Magid¹, Badr Kamoon², Zuhair H Obaid³

Al Furat Al Awsat Technical University. IRAQ
 Email hani_magid@yahoo.com
baderalmamory@yahoo.com
phd.zhh_77@yahoo.com

ABSTRACT

Among many analysis methods, sensitivity analysis is one of a significant method used for many engineering solutions in many applications like the major uncertainties, model validation, model refinement and decisions making. There are different challenges in optimization and improvement of engineering products, like products life, esthetical shape, weight and durability. The main objectives of this work are to optimize the shape geometry and increase the service life of the product by determining and then minimizing the stresses concentration through predicting the influence of any change in geometry to recommend the optimum design. Sensitivities measurement is normally calculated based on computational technique conjunction with direct differentiation method. In this work, Finite element software under ABAQUS/CAE code has been adopted for analysis and simulation. In ABAQUS, and by default; appropriate perturbation can be determine automatically depend on a heuristic algorithm by using central differencing method. In this work; rubber brace are used for analysis, and the main design parameters used to specify the product sensitivity of the final geometry are: product thickness, small fillets and modules of elasticity. A reasonable result has been estimated in terms of stresses and product dimensions. Due to nonlinearity behavior; the reduction in stresses concentration is about 9%, and the product fillet yields to new values with small increment due the variable mass scaling used in boundary conditions. As results of this analysis, the zones of high stress values are specified, and the most effecting parameters on this stresses are determined. It's concluded that this technique is useful for many features like contacts, viscoelasticity and also in nonlinear analyses. Even more, sensitivity analysis can used to develop and improve the design before any further analysis.

Keywords

Sensitivity analysis, Design, ABAQUS, Finite element, and Optimization.

Introduction

The systematic procedure to determine the influence of some selective parameters on the output results is called Sensitivity analysis. It's a systematic procedure to quantify and define the uncertainty due to many factors

like, input uncertainty, data variability, and model imprecision [1]. To facilitate the modifications of any structure and to estimate the parts sensitivity according to design parameters, its advise to adopt design sensitivity analysis method. Constraints definitions in this method will be imposed on displacement, stress, and strain, and these constraints will apply at elements for displacements, and apply at nodes for strain and Stress components [2]. Nowadays computational methods are very imports in different scientific applications. However, Sensitivity analysis is one of computational tools to find the influence of input parameters on the results, and estimate the most influencing factors, and finally to evaluate each factor separately [3]. The procedure in design sensitivity analysis is to use the nodal coordinates of mesh to estimate the derivatives of finite element solution. Sensitivity analysis for geometrical shape design is consider as a one of the most crucial method for, optimization, but in same time it's still difficult and elaborates even for some linear applications [4]. The finite element method is used to find the approximate solution for the partial differential equations by dividing the large spaces and quantities to smaller and smaller by using different types of meshing technique called finite elements. Finite element software are extensively used in many design and modelling applications and can get a numerical response by calculating the initial boundary conditions values for the specific model [5]. Choosing design parameters for any product design optimization is the starting point for design sensitivity analysis. Many aspects can follow in calculation of design sensitivity like, analytical reliability, optimization method and reliability-based structural [6]. To specify the main important exposure of risk factors and to mitigate the risk influence by developing some idea, sensitivity analysis is a better systematic tool which can use the risk model to specify these factors. In order to determine the major uncertainties or priority in data research collection, or to validate and verify the major variables in model refinement or development; sensitivity analysis will be the main solution method for these cases. [7]. During development and research, the important things for productivity improvement is to use the robust design as a determination methodology to control the sensitive factors and then enhance the

products quality and minimize the production cost [8.11]. In this time being; sensitivity analysis is used in many complex engineering applications as a better solution for analysis proposes in many fields like physics, economics and medical decision making [9, 10].

Parts Geometry and Materials Properties

The product under analysis in this research is a rubber brace used in some automobile services. "Fig. 1".A. and B. illustrates the geometry of this product in two dimensions and three dimension respectively.

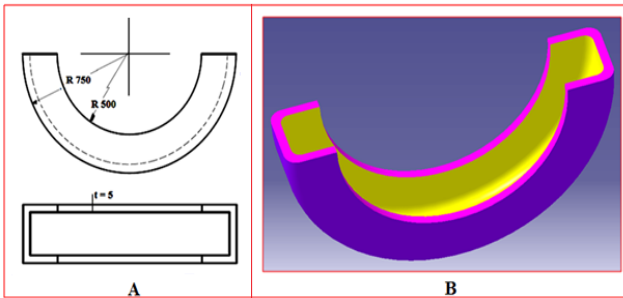

"Fig. 1". A. Product in two dimensions; and B. In three dimension.

The mechanical properties of rubber pad used in this work are listed in "Table 1".below.

Table 1: Mechanical properties of rubber used.

No.	Properties	Values
1	Density (kg/m ³)	1.1x10 ⁻⁹
2	Poisson's Ratio	0.499
3	Young Modulus (MPa).	1.59
4	Tensile strength (MPa).	15.95
5	Hardness (Shore A)	67
6	Strain Energy (MJ/m ³)	2.2

The forming process used to produce this rubber brace are consist of some steel parts (punch and die). The geometry of these parts or tools is modelled according to the requirements to form and produce the product under study. "Fig. 2".illustrate the model assembly of these tools under action.

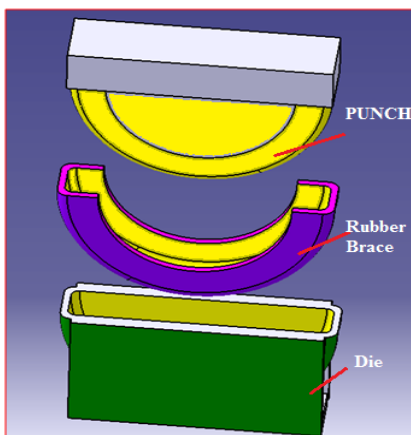

"Fig. 2". Assembly model of tools used in forming the rubber pad. Conclusions

Finite Element Simulation and Sensitivity Analysis

The main purpose for this analysis is to determine and to demonstrate the effects of some sensitivity aspects design features on the product properties. For this sample under analysis; many influences on responses such as natural frequencies and contact .pressure are explored by design sensitivity analysis ABAQUS/ CAE design has a powerful technique in demonstrating and using the sensitivity analysis in nonlinear features problems like contact and viscoelasticity. In this finite element code, there are many options are available for such types of analysis like analyzing and building the multiple .parts model in one model

In the starting of this analysis, some boundary conditions must impose to constrain some parts from any movement, and in same time apply a pressure load to force the punch to move downward. "Fig. 3".Illustrate the assembly model .under constrain

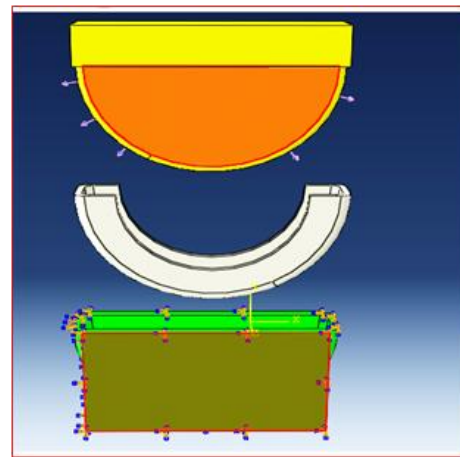

"Fig. 3". Boundary conditions on the assembly model.

To find the suitable values for the most sensitive parameters which have major effects on the product functions and to simplify the solution, it's important to partition and divide the product under analysis to difference regions. "Fig. 4". A. and B. illustrate this method.

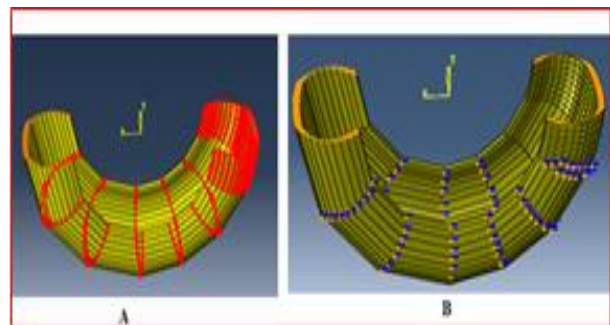

"Fig. 4". A.; B. Part partitioning.

Adaptive mesh (4-node quadrilaterals) is used to capture the wide ranges of element and nodes along part surfaces. Meshed assembly is shown in "Fig. 5".

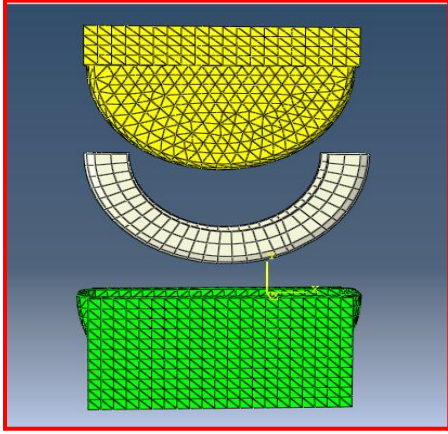

"Fig. 5". Meshed assembly

Mesh refinement can enhance the results and increase the results accuracy through generations a lot of elements. By using element labels option it's possible to numbering all elements around the product surfaces which enable us to find the required value for each element and points exactly. "Fig.6".and"Fig. 7".illustrate the nodal and elements labels in different positions.

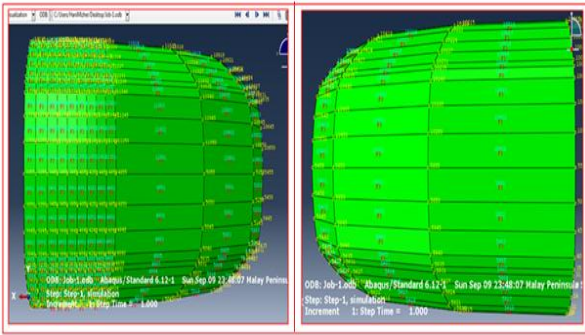

"Fig. 6". Elements and nodal label in to different positions.

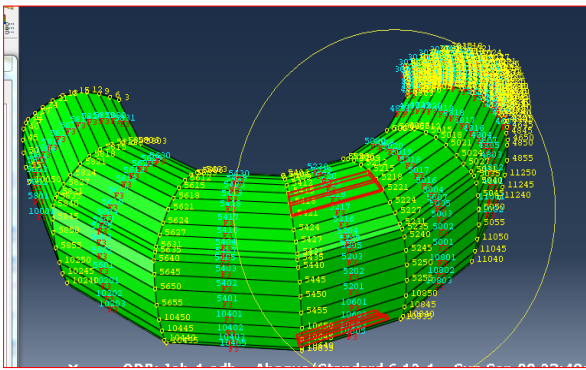

"Fig. 7". Elements label along perimeter.

There are some designs parameters are selected for this analysis. The first parameter is product thickness (t), and the second parameter is elastic modulus of the rubber (E). The primary thickness is considered as (t_0), and the change in thickness will be (t_1), and that's means:-

$$t_1 = t_0 * k \quad (1)$$

Where (k) is a ratio of (t_1 / t_0).

That's means there is a proportional between (t_1) and (t_0). The other design parameters used is elastic modulus of rubber material (E), and finally the rubber density (ρ) is the last design parameter used for verification and demonstration purposes. To compute sensitivities; (ABAQUS/CAE) always use the approach of semi-analytic, because this approach involve computation of finite difference in many elements level, and by default it can determines automatically the perturbation sizes for each element to use in computations the finite differencing through heuristic sizing algorithm. The option (CONTROL) is normally used to register any changes in element size, and the effects of these changes on whole sensitivities of the specific parameter. For larger parts problem; and if cannot know the suitable or exact perturbation sizes of elements, then it's possible to use the default sizing algorithm to run a smaller problem, and the results that found by (ABAQUS) can inserted to find the big element sizing.

Results and Discussion

This paper explains the characterization of sensitivity analysis in order to determine their effect on geometrical optimization. In this analysis, there are three main steps: load control step, frequency extraction step and displacement control step. In each step, sensitivity analysis is implemented as design response in both frequency and static steps

In this analysis, and for comparison purposes; some sensitivities results should be normalized. Normalizing the corresponding sensitivities and the contact pressures by dividing each value on maximum pressure is very important. Even more; it should multiply the contact pressure by design parameter value

The important factors on this rubber product is the contact pressure and logarithmic strain values, because it can be related to the wear properties, so the sensitivity analysis results are discussed here depending on the whole distribution of contact pressure and strain values. The contour of logarithmic strain in "Fig. 8".show the average strain values distribution. The maximum strain value located in part one at element (11038).

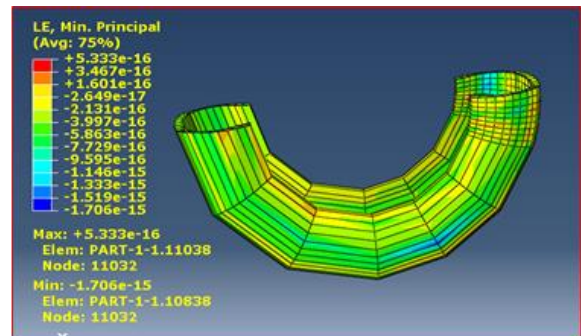

"Fig. 8". Contour of logarithmic strain

The main approach in this simulation is to use the results of sensitivity analysis for modification of contact pressure distribution, stress and strain in the best form according to the design parameters, so that the product will be carry more load, more serve life and better durability. There are many differences in contact pressure distribution around the product. Pressure values outside perimeter region are more than the center region. Pressure contour in "Fig. 9". illustrate the

pressure distribution, and show that, there are a lot of variations observed in the values of sensitivities in the regions far from the product center.

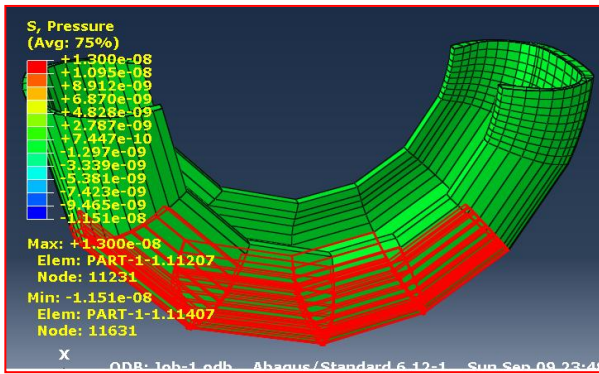

"Fig. 9". Contour of pressure distribution.

It can be estimated that these variations is due to the high gradients in pressure in each zone and around the product center, so any change in design parameters will leads to some differences in contact pressure.

Pressure increase will lead to generate different types of stresses along the outside product perimeter and in canter area. Contour of horizontal stresses are shown in "Fig. 10".

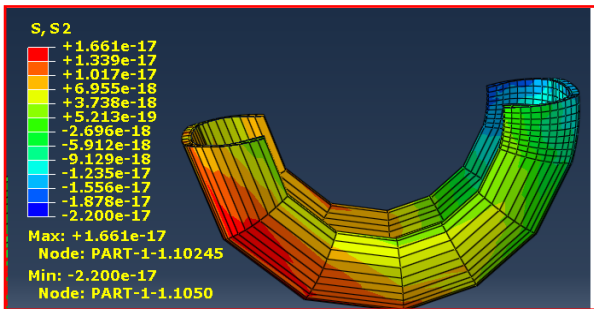

"Fig. 10". Contour of horizontal stresses.

Sensitivity contours revealed that any increase in contact pressure will lead to increase in modulus of elasticity (E), but the thickness value (t) will decrease. Regarding to the normalized sensitivities magnitudes; the value of (E) has the major effects on contact pressure, especially in the center of the part. According to the increase in design parameter value (E), a new design should be investigated

The new run after normalization above show that there is a uniform stresses distribution along the part surfaces, and also the material orientation is arranged uniformly in each partition. Contour plot of Von-mises stresses and material orientation are illustrated in "Fig. 11". and "Fig. 12". respectively.

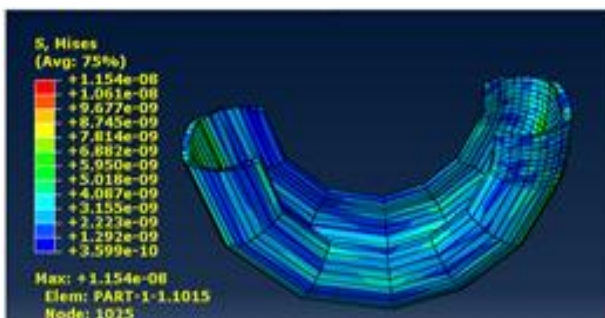

"Fig. 11". Contour plot of Von-mises stresses.

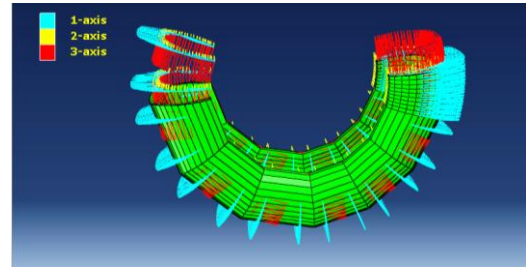

"Fig. 12". Contour plot of material orientation.

The percentage of increase in sensitivity is about 2.32%, which is familiar with such nonlinearity problems. The frequency sensitivities give a clear vision on the design dynamic behavior. It's concluded that the frequency value is high sensitive to the thickness and low sensitive for young's modulus of elasticity (E). "Table 2". illustrate the natural frequency values with the corresponding sensitivities for the product. It can be estimate from this table that natural frequency is independent on the design parameters. Results show that, the simultaneous changes by using sensitivity results will be true only when there's a small variation in design parameters.

Table 2: Natural frequency values with the corresponding sensitivities.

Mode No.	Frequency Value	Normalized frequency sensitivity with respect to:-		
		(t)	(ρ)	E
1	58.7	1.45E-1	-5.69E-1	2.27E-3
2	51.6	1.56E-1	-5.00E-1	-1.84E-3
3	52.9	2.18E-1	-5.13E-1	-1.81E-5
4	58.7	1.45E-1	-5.69E-1	2.27E-3
5	60.6	1.34E-1	-5.88E-1	1.75E-3

As example, when design parameter like (E) increase, and the other parameter (t) increase in same percent, then the pressure will increase about halve of each one of the last values. Simultaneous changes in sensitivities cannot happen, and also large variations and changes cannot expect because the sensitivities are first-order derivatives. "Fig.13". illustrate the simultaneous changes between sensitivity of product thickness to the applied pressure.

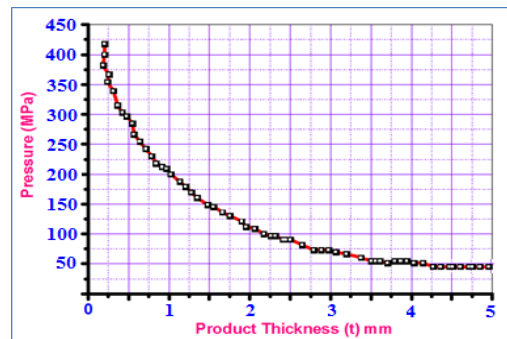

"Fig.13". Sensitivity of product thickness to the applied pressure.

The relationship between the uncertainty of model input parameter and the sensitivity of the output variable of the model are shown in "Fig.14". as a comparison between two cases.

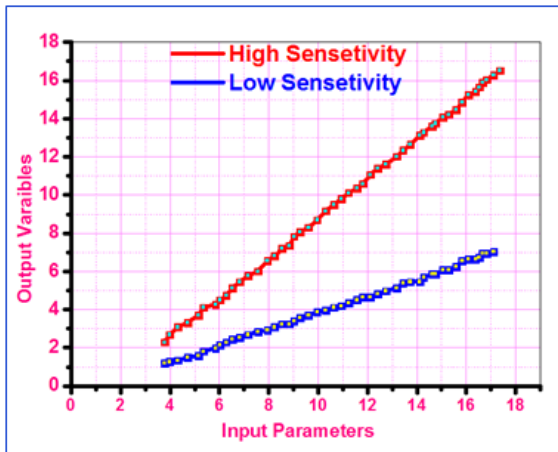

"Fig. 14". Relationship between uncertainty input and sensitivity of output.

The Sensitivity of nodal displacement to the applied force during the forming process is shown in "Fig.15". Variation in the nodal incremental displacement may due to differences in boundary conditions for each zone.

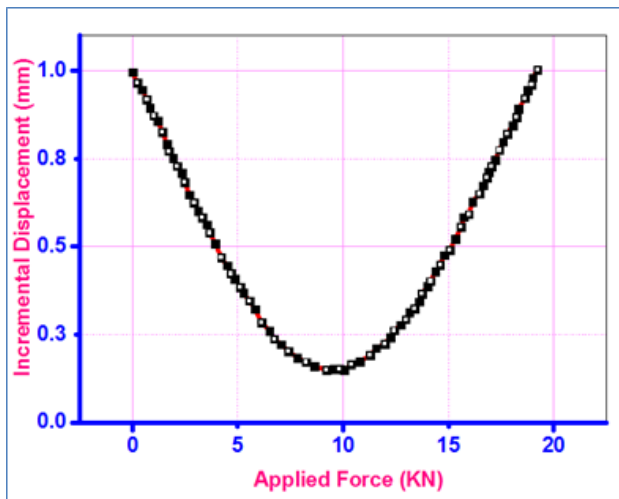

"Fig. 15". Relationship between nodal incremental displacement and force.

Conclusions

The following conclusions have been found:-

1. Sensitive analysis is very useful tool specially when integrated with finite element method. It can provide an effective help for the designer engineer to improve the product under early investigation.
2. Sensitivity for shrinkage in elastomer products can minimizes.
3. Systematic assessment can provide by Sensitivity analysis on output values and performance by relative error contribution with others uncertainty parameters.
4. Model development is possible whenever the key parameters are identified, and then extend the solution to reduce the uncertainty in whole model.
5. Accurate sensitivities can provide an improvements by enhance the tangent stiffness and convergence tolerances.

References

Zoltan Budavari and Zsuzsa Szalay, EMI Nils Brown and Tove Malmqvist, KTH. (2011). "Methods and guidelines for sensitivity analysis, including results for analysis on case studies". FP7-ENV-1 -LoRe-LCA-212531. LoRE-LCA-Deliverable 5.2 Final version Page 4 of 46.

MSC.Marc. Version (2001). Theory and user Information. Volume A, Page 226. MSC. Software Corporation U. S. A.Author A. (1986). Book Name. Publisher Name, Address.

E. Burnaev, I. Panin and B. Sudret. (2017). "Efficient Design of Experiments for Sensitivity Analysis Based on Polynomial Chaos Expansions".Annals of Mathematics and Artificial Intelligence. <http://arxiv.org/abs/1705.03947>.

Raino Mäkinen. (2009). Finite Element Design Sensitivity Analysis for Nonlinear Potential Problems. University of Jyväskylä. Finland. <http://users.jyu.fi/~rainom/>

Yang Zhao. (2016). "Global Sensitivity Analysis of Mat Foundation Behaviour by Using Finite Element Modelling". Master Thesis. Faculty of Old Dominion University. https://digitalcommons.odu.edu/cee_etds.

Young H. Park, Nam H. Kim, Hong J. Yim. (2000). "Reliability-Based Design Sensitivity Analysis and Optimization for the Hyper-Elastic Structure Using the Meshfree Method". Proceedings of 2000 ASME Pressure Vessels and Piping Conference, Seattle, WA, July 23-27.

H. Christopher Frey, Sumeet R. Patil, (2005). " Identification and Review of Sensitivity Analysis Methods". Civil Engineering Department, North Carolina State University.

Amit Jaisingh, K. Narasimhan , P.P. Date , S.K. Maiti , U.P. Singh. (2004). "Sensitivity analysis of a deep drawing process for miniaturized products". Journal of Materials Processing Technology 147 . 321–327. www.elsevier.com/locate.

B. Iooss, P. Lemaître. (2015) "A review on global sensitivity analysis methods. In: Meloni C, Dellino G (eds) Uncertainty management in Simulation-Optimization of Complex Systems". Algorithms and Applications, Springer.

Bendsøe, M. P., E. Lund, N. Ohloff, and O. Sigmund. (2005). "Topology Optimization - Broadening the Areas of Application," Control and Cybernetics, vol. 34, pp. 7–35,.

Hansen, L. V. (2005). "Topology Optimization of Free Vibrations of Fiber Laser Packages," Structural and Multidisciplinary Optimization, vol. 29(5), pp. 341–348.